

Installation & Maintenance Instructions

2-WAY PILOT-OPERATED OR DIRECT – ACTING SOLENOID VALVES
NORMALLY CLOSED OPERATION — 3/4", 1", 1 1/4" OR 1 1/2" NPT
FUEL GAS SERVICE

SERIES

K3A6
K3A7

I&M No.V8501R2

Service Notice

Except for coil replacement, the Series K3A6 and K3A7 are not repairable. When any performance problems are detected during routine inspection, replace valve immediately.

DESCRIPTION

Series K3A6 and K3A7 valves are 2-way normally closed solenoid valves designed for fuel gas service. Series K3A6 is a pilot-operated solenoid valve, while Series K3A7 is direct-acting. Valve bodies are made of rugged aluminum with trim and internal parts made of steel and stainless steel. These valves are provided with a general purpose junction box solenoid enclosure.

Provisions for Pressure and Seat Leakage Testing

Series K3A6 and K3A7 valves are provided with two 1/8" NPT tapped and plugged holes (pressure taps). The upstream tapped and plugged hole is on the side of the valve body; downstream on the bottom of the valve body. One upstream for pressure testing; one downstream for seat leakage testing. Leakage testing frequency shall be at least annually in accordance with NFPA-86 or original equipment manufacturer recommendations. For instructions, refer to section on *Testing for Internal (Seat) Leakage* and Figure 3.

Partial view of valve body showing location of tapped and plugged holes for pressure and seat leakage testing

Pipe plugs are 1/8" NPT
(use 3/16" Hex Key Wrench)

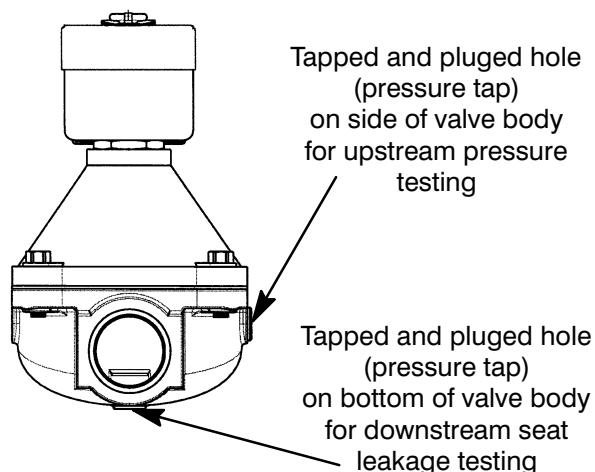

Figure 1. Provisions for pressure and seat leakage testing.

OPERATION

Normally Closed: Valve is closed when solenoid is de-energized; open when energized.

Note: No minimum operating pressure differential required.

INSTALLATION

Check nameplate for correct catalog number, pressure, voltage, frequency, and service. Never apply incompatible fluids or exceed pressure rating of the valve. Installation and valve maintenance to be performed by qualified personnel.

Temperature Limitations

Wattage Coil Class	Nominal Fluid Temperature	Ambient Temperature Range
20 / N	77°F (25°C)	-40°F (-40°C) to 175°F (80°C)

Positioning

Valve must be mounted with solenoid vertical and upright or in a horizontal position only.

Piping

CAUTION: Piping must comply with applicable local and national codes and ordinances, including the National Fuel Gas Code ANSI Z223.1/NFPA No. 54.

Connect piping to valve according to flow arrow on bottom of valve body. Apply pipe compound sparingly to male pipe threads only. If applied to valve threads, the compound may enter the valve and cause operational difficulty. Avoid pipe strain by properly supporting and aligning piping. When tightening the pipe, do not use valve or solenoid as a lever. Locate wrenches applied to valve body or piping as close as possible to connection point. Valve should be checked for external leakage at piping connections after installation, see *Testing for External Leakage* section.

CAUTION: To avoid damage to the valve body, DO NOT OVERTIGHTEN PIPE CONNECTIONS. If PTFE tape, paste, spray, or similar lubricant is used, use extra care when tightening due to reduced friction.

CAUTION: To protect the solenoid valve, install a strainer or filter, suitable for the service involved, in the inlet side as close to the valve as possible. Clean periodically depending on service conditions. See ASCO Series 8600, 8601 and 8602 for strainers.

Wiring

Wiring must comply with local codes and the National Electrical Code. To facilitate wiring, the solenoid enclosure may be rotated 360°. The junction box housing has two 7/8" diameter knockouts to accommodate 1/2" conduit. Drive out appropriate knockout with junction box completely assembled (with cover) for support. Remove "J" box cover, by spreading cover and disengaging nibs (lift up and pull down simultaneously). The junction box is provided with a grounding screw (green) and a corresponding hole in the housing for the grounding connection. Within the junction box solenoid enclosure use field wire that is rated 125° C or greater for connections. Replace "J" box cover before operating.

Testing for External Leakage

▲ WARNING: To prevent the possibility of death, severe personal injury or property damage, extinguish all open flames and avoid any type of sparking or ignition.

1. Block gas flow on downstream side of valve.
2. Apply pressure to valve within nameplate rating and energize solenoid.
3. Apply a soapy solution or a commercially available leak detecting solution to the pipe connections and check for bubbles. If the valve has been tested for seat leakage, apply the solution around the pipe plugs.
4. If leakage exists, depressurize valve and turn off electrical power supply. Tighten connections as required and retest following the above steps.

Solenoid Temperature

Series K3A6 and K3A7 valves are supplied with coils designed for continuous duty service. When the solenoid is energized for a long period, the solenoid enclosure becomes hot and can be touched with the hand for an instant. This is a safe operating temperature. Any excessive heating will be indicated by the smoke and odor of burning coil insulation.

MAINTENANCE

▲ WARNING: To prevent the possibility of death severe personal injury or property damage, turn off electrical power, depressurize valve, extinguish all open flames and avoid any type of sparking or ignition. Vent hazardous or combustible fluid to a safe area before inspection or removing the valve from service.

Preventive Maintenance

- Keep medium flowing through the valve as free from dirt and foreign material as possible.
- Periodic exercise of the valve should be considered if ambient or fluid conditions are such that corrosion, elastomer degradation, fluid contamination build up, or other conditions that could impede solenoid valve shifting are possible. The actual frequency of exercise necessary will depend on specific operating conditions. A successful operating history is the best indication of a proper interval between exercise cycles.

- Depending on the medium and service conditions, periodic inspection of internal valve parts for damage or excessive wear is recommended.

NOTE: For performance problems, refer to *Troubleshooting Chart* on page 4 of 4.

Coil Replacement (Refer to Figure 2)

NOTE: It is not necessary to remove the valve from the pipeline for *Coil Replacement*.

▲ CAUTION: Exercise care to prevent damage to the solenoid base sub-assembly. Do not grasp solenoid base sub-assembly with wrench or pliers.

1. Disconnect supply wires to coil and rigid conduit from junction box.
2. Remove retaining clip from top of solenoid.

▲ CAUTION: When metal retaining clip disengages, it will spring upward.

3. Remove cover and spring washer.
4. Slip yoke containing coil and sleeves off solenoid base sub-assembly.
5. Coil is now accessible for replacement.
6. Reassembly in reverse order of disassembly using a new coil replacement.
7. Make electrical connections to solenoid, see *Wiring* section.

Valve Disassembly

1. Disassemble valve in an orderly fashion. Paying careful attention to exploded view for identification and placement of parts. See Figure 2.
2. Remove retaining clip from top of solenoid and remove solenoid enclosure. If rigid conduit is used, remove "J" box cover by lifting up and pulling down on cover simultaneously. Disconnect conduit, grounding wire and supply wires to coil.

▲ CAUTION: When metal retaining clip disengages, it will spring upward.

3. Remove bonnet screws and lift valve bonnet off valve.
4. Parts are now accessible for inspection, cleaning or replacement. If parts are worn or damaged, replace valve.

Valve Reassembly

1. Reassemble valve paying careful attention to exploded view. Position valve bonnet onto valve body. Be sure bleed hole in diaphragm is in proper location, perpendicular to inlet and outlet. (See Figure 2)
2. Hand thread bonnet screws into valve body as far as possible. Then torque bonnet screws in a crisscross manner to 25 – 35 in-lbs [2,8 – 3,9 Nm].
3. Install solenoid. Install retaining clip.
4. Restore electrical power supply to valve.
5. After maintenance is completed, operate the valve a few times to be sure of proper operation. A metallic *click* indicates the solenoid is operating.

▲ CAUTION: Solenoid must be fully reassembled because the housing and internal parts are part of and complete the magnetic circuit.

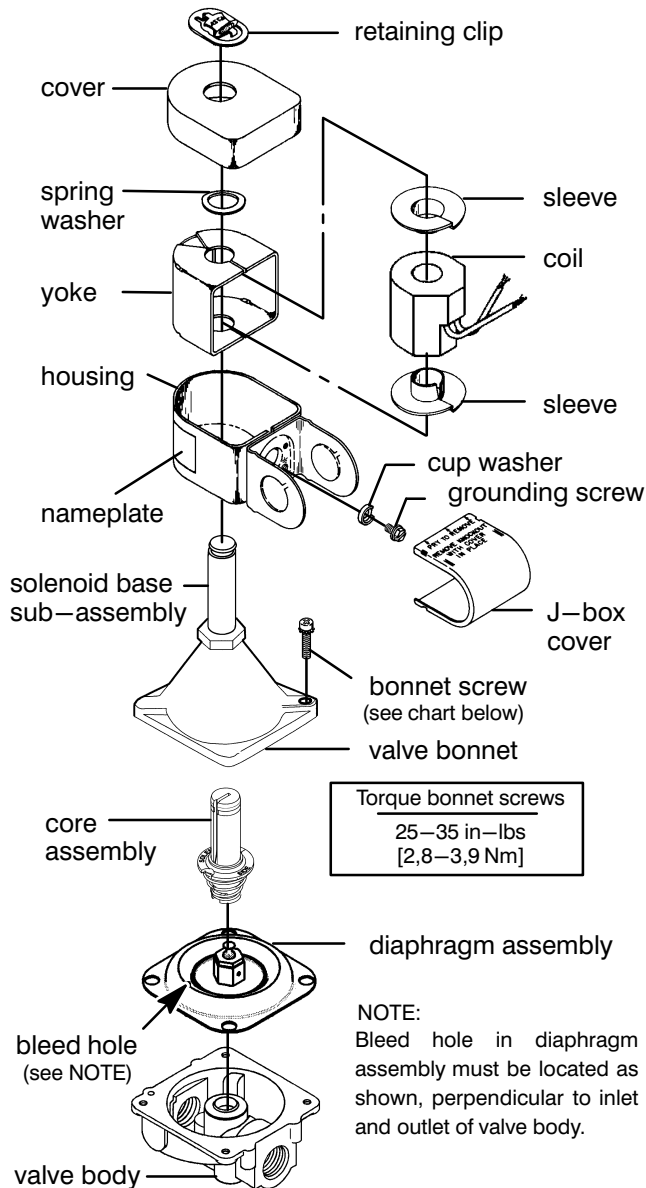

Figure 2. Exploded view, typical K3A valve.

Testing for Internal (Seat) Leakage (Refer to Figure 3)

CAUTION: Be sure valve can be tested without affecting other equipment.

1. Shut off both the upstream and downstream manual gas cocks. The downstream manual gas cock should remain closed throughout the entire test procedure.
2. Program the control system to operate the valve through five cycles. Listen carefully for the solenoid coil to *click* indicating proper operation.
3. Open the upstream manual gas cock. Program the control system to energize and maintain the valve in the open (energized) position. Check all valve and piping connections for external leaks with rich soap and water solution or a commercially available leak detecting solution.
4. Shut off the upstream manual gas cock and de-energize valve. Remove the plug from the leak test tap or downstream pressure tap in the valve body. Connect leak

test equipment with the test petcock in the closed position (Figure 3).

5. Open the upstream manual gas cock. Program the control system to energize the valve to the full open position, then immediately de-energize it to seat the valve operationally.
 6. Immerse the 1/4" leak test tube vertically into a jar of water to a depth of about 1/2". Slowly open the test petcock. Bubbles may appear in the water as the pressure equalizes.
 7. After the rate of bubbles coming through the water stabilizes, count the number of bubbles appearing in a 10 second period. The allowable leakage in 10 seconds for an orifice diameter of 1 inch (25.4 mm) or less is 6 bubbles (3 cc/min). For valves with an orifice diameter over 1 inch (25.4 mm) the allowable leakage rate is 6 bubbles (3 cc/min.) per inch (25.4 mm) of orifice diameter. If leakage exceeds this rate, replace valve.
- NOTE:** The leakage rate above recognizes that some wear and contamination from use can result in a slight amount of leakage. The allowable leakage rate is well within the leakage limits as recognized by applicable approval agencies.
8. Close the upstream manual gas cock and the test petcock. Then remove the test equipment. Apply a small amount of Loctite Corporation's PST® Pipe Sealant 567 (or equivalent) to the pipe plug threads. Reinstall the pipe plug and tighten securely.
 9. Turn on the gas supply at the upstream manual gas cock and energize the valve.
 10. Open the upstream manual gas cock. Program the control system to energize and maintain the valve in the open (energized) position. Check all valve and piping connections for external leaks with rich soap and water solution or a commercially available leak detecting solution.
 11. De-energize the valve. Open the downstream manual gas cock.
 12. Restore the system to normal operation.

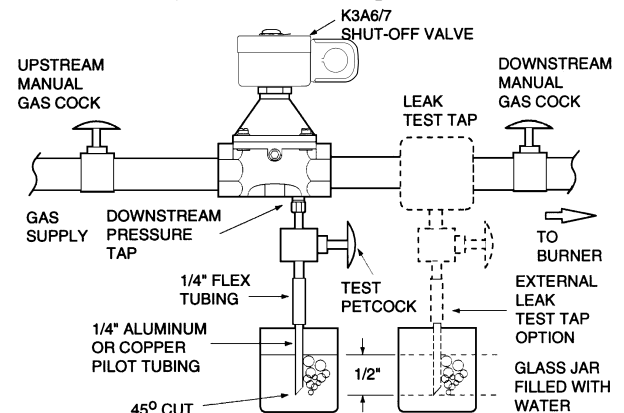

Figure 3. Testing for internal seat leakage.

ORDERING INFORMATION FOR COIL REPLACEMENT

When ordering coils, specify valve catalog number, voltage and coil number, if possible.

Troubleshooting Chart

Trouble	Possible Cause	Remedy
Valve operation is sluggish	<p>Solenoid coil short, or wrong voltage.</p> <p>Damaged internal parts.</p> <p>Dirt or other foreign matter restricting operation of valve.</p>	<p>Check coil voltage. Replace solenoid coil.</p> <p>Replace valve.</p> <p>Replace valve and install strainer upstream of valve.</p>
Valve fails to open	<p>Timer, limit controls or other devices not energizing circuit.</p> <p>Damaged internal parts preventing core operation.</p> <p>Solenoid coil short, burned-out or wrong voltage.</p> <p>Dirt, pipe compound or other foreign matter restricting operation of valve.</p>	<p>Check circuit for limit control operation, blown fuse, short circuit and loose wiring.</p> <p>Replace valve.</p> <p>Replace with solenoid coil of correct voltage</p> <p>Replace valve and install strainer upstream of valve.</p>
Valve fails to close	<p>Damaged internal parts preventing core operation.</p> <p>Dirt, pipe compound or other foreign matter restricting operation of valve.</p> <p>Limit controls improperly installed to grounded side.</p>	<p>Replace valve.</p> <p>Replace valve and install strainer upstream of valve.</p> <p>Wire controls in hot side of circuit.</p>
Valve "chatters"	<p>Valve supply voltage is improper (too low)</p> <p>Dirt or chips between top of core assembly and solenoid base sub-assembly.</p>	<p>Apply correct voltage to valve.</p> <p>Replace valve and install strainer upstream of valve.</p>